

# NL1000 Series User's Manual

## 1. Preface

Thank you for choosing NL1000 series of high-performance, Simple inverter. Diagram of the operating instructions, is to facilitate the description, may be slightly different with the product.

Please note that this manual will be handed the hands of end users, and retain for future maintenance, use and If in doubt, please contact with our company or agent of the Company to get in touch, we will be happy to serve you.

## 2. Nameplate Description

**MODEL: NL1000-1R5G-2**

INPUT: 1PH 220V 50Hz/60Hz

OUTPUT: 3PH 220V 7.0A 150% 60S

FREQ RANGE: 0.1-400Hz 1.5KW



1105080001-3051



Model: NL1000 - 1R5G - 2

Voltage range :

2: 1PH AC220V INPUT

4: 3PH AC 380V INPUT

Inverter capacity:01R5means 1.5kW  
NL1000 Series

## 3. Dimensions

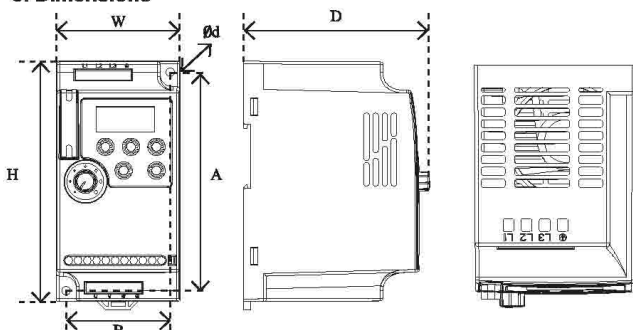

**Note:** Support for standard 35 mm rail mounting

Unit: mm

Model	W	H	D	A	B	Ød
NL1000-00R4G2-NL1000-01R5G2	68	132	102	120	57	4.5
NL1000-02R2G2	72	142	112.2	130	61	4.5
NL1000-00R7G4-NL1000-02R2G4						
NL1000-03R7G4-NL1000-05R5G4	85	180	116	167	72	5.5
NL1000-07R5G4-NL1000-011G4	106	240	153	230	96	4.5
NL1000-015G4-NL1000-022G4	151	332	165.5	318	137	7
NL1000-030G4-NL1000-037G4	217	400	201	385	202	7
NL1000-045G4-NL1000-055G4	300	470	240	455	200	4.5

## 4. Keyboard Description

**RUN/FWD/REV/STOP:**

Status indicator: Various operation status

**Display area: displays:**

set frequency, operating frequency, current, and abnormal values for each parameter setting content

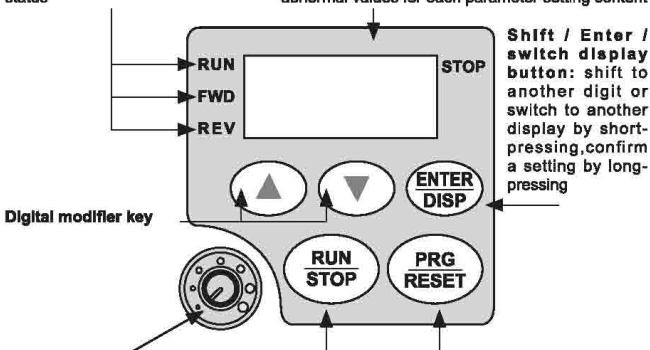

Turn to another frequency by rotating the potentiometer when the frequency is set to be controlled by the manipulator potentiometer

**Run / Stop button:** Click Run, and then click Stop

**Programming key / fault reset button:** short press for programming key, press 2 seconds for the fault reset button

## 5. Product Specifications

Items	NL1000	
Power Supply	Rated voltage, Frequency	1PH/3PH AC 220V 50/60Hz; 3PH AC380V 50/60Hz
	Voltage Range	220V: 170V~240V; 380V:330V~440V
Output	Voltage Range	220V: 0~220V; 380V:0~380V
	Frequency Range	0.10~400.00Hz
Control method	V/F control, Space vector control.	
Indication	Operating status/Alarm definition/interactive guidance: eg, frequency setting, the output frequency/current, DC bus voltage, the temperature and so on.	

Items		NL1000
Control Specifications	Output Frequency Range	0.10Hz~400.00Hz
	Frequency Setting Resolution	Digital input : 0.1 Hz, analog input: 0.1% of maximum output frequency
	Output Frequency Accuracy	0.1Hz
	V/F Control	Setting V/F curve to satisfy various load requirements.
	Torque Control	Auto increase: auto raise torque by loading condition; Manual increase:enable to set 0.0~20.0% of raising torque.
	Multifunctional Input Terminal	Four multi-function input terminals, realizing functions including fifteen section speed control, program running, four-section acceleration/deceleration speed switch, UP/DOWN function and emergency stop and other functions
	Multifunctional Output Terminal	1 multi-function output terminals for displaying of running, zerospeed, counter, external abnormality, program operation and other information and warnings.
	Acceleration/ deceleration Time Setting	0~999.9s acceleration/deceleration time can be set individually.
Other Functions	PID Control	Built-in PID control
	RS485	Standard RS485 communication function (MODBUS)
	Frequency Setting	Analog input:0 to 10V, 4 to 20mA can be selected; Digital input: Input using the setting dial of the operation panel or RS485or UP/DOWN. Note: AVI terminals can be used to select an analog voltage input (0-10V) and analog current input (4-20mA) through the switch J2.
	Multi-speed	Four multifunction input terminals, 15 section speed can be set
	Automatic voltage regulation	Automatic voltage regulation function can be selected
	Counter	Built-in 2 group of counters
Protection/ Warning Function	Overload	150%, 60second (Constant torque)
	Over Voltage	Over voltage protection can be set.
	Under Voltage	Under voltage protection can be set.
	Other Protections	Output shortcircuit, over current, and parameter lock and so on.
Environment	Ambient Temperature	-10°C to 40°C (non-freezing)
	Ambient Humidity	Max. 95% (non-condensing)
	Altitude	Lower than 1000m
	Vibration	Max. 0.5G
Structure	Cooling Mode	Forced air cooling
	Protective Structure	IP 20
Installation	Mode	Wall-mounted or standard 35MM rail mounting

## 6.Wiring

Note: When using a single-phase power supply, please access from terminals L1 and L2

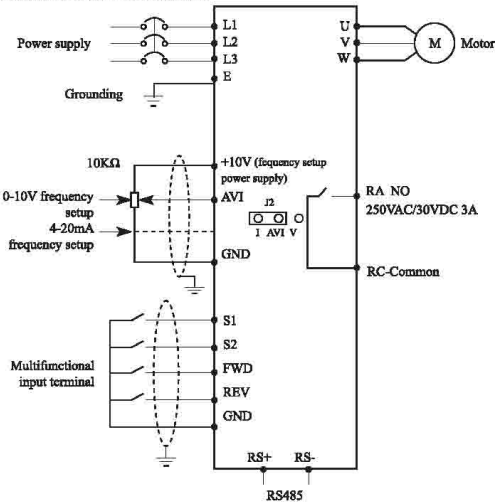

Note: AVI terminals can be used to select an analog voltage input (0-10V) and analog current input (4-20mA) through the switch J2.

## 7.Parameters

Function	Parameters	Name	Setting Range	Minimum Setting increments	Initial value
Monitor functions	P000	Main display data selection	0-32	1	1
	P001	Display the set frequency	Read only	----	----
	P002	Display the output frequency	Read only	----	----
	P003	Display the output current	Read only	----	----
	P004	Display the motor speed	Read only	----	----

Function	Parameters	Name	Setting Range	Minimum Setting Increments	Initial value
Monitor functions	P005	Display the DC bus voltage value	Read only	-----	-----
	P006	Display the temperature of inverter	Read only	-----	-----
	P007	Display PID	Read only	-----	-----
	P010	Alarm record 1	Read only	-----	-----
	P011	Alarm record 2	Read only	-----	-----
	P012	Alarm record 3	Read only	-----	-----
	P013	Alarm record 4	Read only	-----	-----
	P014	The frequency setting in the last alarm	Read only	-----	-----
	P015	The output frequency in last alarm	Read only	-----	-----
	P016	The output current in last alarm	Read only	-----	-----
P017	The output voltage in last alarm	Read only	-----	-----	
P018	The output DC bus voltage in last alarm	Read only	-----	-----	
Basic functions	P100	Digital frequency setting	0.00—Maximum frequency	0.1	0.0
	P101	Frequency setting selection	0: Digital frequency setting (P100) 1: Analog voltage (0—10VDC) 2: Analog current(0—20mADC) 3. Setting dial (Operation panel) 4 UP/DOWN frequency setting 5: RS485 communication frequency setting	1	3
	P102	Start signal selection	0: Operation panel (FWD/REV/STOP) 1: I/O terminal 2: Communication (RS485)	1	0
	P103	“stop” key lock operation selection	0: “Stop” key lock mode invalid 1: “Stop” key lock mode valid	1	1
	P104	Reverse rotation prevention selection	0: Reverse rotation disallowed 1: Reverse rotation allowed	1	1
	P105	Maximum frequency	Minimum frequency~400.00Hz	0.1	50.0
	P106	Minimum frequency	0.00~maximum frequency	0.1	0.00
	P107	Acceleration time 1	0~999.9s	0.1	Depends on models
	P108	Deceleration time 1	0~999.9s	0.1	
	P109	V/F maximum voltage	V/F intermediate voltage ~ 500.0V	0.1	Depends on models
	P110	V/F base frequency	V/F intermediate frequency ~ max. frequency	0.1	50.00
	P111	V/F intermediate voltage	V/F minimum voltage ~ V/F maximum voltage	0.1	Changing
	P112	V/F intermediate frequency	V/F minimum frequency ~ V/F base frequency	0.01	2.50
	P113	V/F minimum voltage	0~V/F intermediate voltage	0.1	15.0
	P114	V/F minimum frequency	0~V/F intermediate frequency	0.1	1.25
	P115	Carrier frequency	1.0K-15.0K	0.1	Changing
	P116	Automatic carrier line up	Reserved	1	0
	P117	Initialization of parameters	8: Initialization of Factory Setting	1	0
	P118	Parameter lock	0: Unlock parameters 1: Lock up parameters	1	0
	P200	Start mode selection	0: regular start 1: restart after inspection	1	0
P201	Stop mode selection	0: deceleration to a stop 1: coasting	1	0	
P202	Starting frequency	0.10~10.00Hz	0.01	0.5	
P203	Stopping frequency	0.10~10.00Hz	0.01	0.5	
P204	DC injection brake operation current (start)	0~150% rated motor current	1%	100%	
P205	DC injection brake operation time (start)	0~25.0S	0.1	0	
P206	DC injection brake operation current (stop)	0~150% rated motor current	1%	100%	
P207	DC injection brake operation time (stop)	0~25.0S	0.1	0	
P208	Torque boost	0~20.0%	1	0%	
P209	Rated motor voltage	0~500.0V	0.1	Changing	
P210	Rated motor current	0~current of system	0.1	Changing	

Function	Parameters	Name	Setting Range	Minimum Setting increments	Initial value
Basic functions	P211	No load current ratio of motor	0~100%	0.1	40%
	P212	Rated motor rotation speed	0~6000r/min	1	1420
	P213	Number of motor poles	0~20	2	4
	P214	Rated motor slip	0~10.00Hz	0.1	2.50
	P215	Rated motor frequency	0-400.00Hz	0.1	50.00
	P216	Resistance of stator	0-100Ω	0.1	0
	P217	Resistance of rotor	0-100Ω	0.1	0
	P218	Self inductance of rotor	0-1.000H	0.1	0
	P219	Mutual inductance of rotor	0-1.000H	0.1	0
I/O functions	P300	AVI minimum voltage input	0~AV maximum voltage	0.1	0
	P301	AVI maximum voltage input	AV minimum voltage~10V	0.1	10.0
	P302	AVI input filter time	0~25.0S	0.1	1.0
	P303	AVI minimum current input	0~AI maximum current	0.1	4.0
	P304	AVI maximum current input	AI minimum current input~20mA	0.1	20.0
	P305	AVI input filter time	0~25.0S	0.1	2.5
	P306	Reserved	0~FOV maximum voltage	0.1	0
	P307	Reserved	FOV maximum voltage output~10V	0.1	10.0
	P310	Frequency of low analog	0~600.00	0.1	0.00
	P311	Direction of low analog	0/1	1	0
	P312	Frequency of high analog	0~600.00	0.1	50.00
	P313	Direction of high analog	0/1	1	0
	P314	Analog input reverse selection	0/1	1	0
	P315	Input terminal FWD (0~32)	0: Invalid 1: Jog	1	6
	P316	Input terminal REV (0~32)	2: Jog Forward 3: Jog reverse 4: Forward/ reverse	1	7
	P317	Input terminal S1 (0~32)	5: Run 6: Forward 7: Reverse 8: Stop 9: Multi-speed 1 10: Multi-speed 2 11: Multi-speed 3 12: Multi-speed 4	1	18
	P318	Input terminal S2 (0~32)	13: Acceleration/Deceleration terminal 1	1	9
	P319	Reserved	14: Acceleration/Deceleration terminal 2	1	
	P320	Reserved	15: Frequency increase signal (UP) 16: Frequency decrease signal (DOWN)	1	
	P321 (0~32)	Reserved	17: Emergency stop signal 18: Inverter reset signal 19: PID in running 20: PLC in running 21: Start signal for timer 1 22: Start signal for timer 2 23: Counter pulse signal 24: Counter reset signal 25: Memory clear 26: Start winding operation	1	
	P323	Reserved	0: Invalid 1: In running 2: Frequency reached 3: Alarm 4: Zero speed 5: Frequency 1 reached 6: Frequency 2 reached 7: Acceleration 8: Deceleration 9: Indication for under voltage 10: Timer 1 reached 11: Timer 2 reached 12: Indication for completion of phase 13: Indication for completion of procedure	1	
	P324	Reserved	14: PID maximum 15: PID minimum 16: 4-20mA disconnection 17: Overload 18: Over torque 26: Winding operation completed 27: Counter reached 28: Intermediate counter reached 29: Water supply by constant voltage	1	
	P325	Alarm output terminal RA, RC (0~32)	"1" turn on "0" turn off	1	03

Function	Parameters	Name	Setting Range	Minimum Setting increments	Initial value
I/O functions	P326	Reserved	0: Frequency output 1: current output 2: Dc bus voltage 3: Ac voltage 4: Pulse output, 1pulse/ Hz 5: 2pulses/Hz 6: 3 pulses/Hz 7: 6 pulses/Hz	1	
	P327	Reserved		1	
Secondary application	P400	Jog frequency setting	0.00~maximum frequency	0.1	5.00
	P401	Acceleration time 2	0~999.9s	0.1S	10.0
	P402	Deceleration time 2	0~999.9s	0.1S	10.0
	P403	Acceleration time 3	0~999.9s	0.1S	10.0
	P404	Deceleration time 3	0~999.9s	0.1S	10.0
	P405	Acceleration time 4/Jog acceleration time	0~999.9s	0.1S	10.0
	P406	Deceleration time 4/Jog deceleration time	0~999.9s	0.1S	10.0
	P407	Designated value of counter	0~999.9s	1	100
	P408	Intermediate value of counter	0~999.9s	1	50
	P409	Limitation of acceleration torque	0~200%	1%	150%
	P410	Limitation of constant speed torque	0~200%	1%	00
	P411	Over voltage prevention selection in deceleration	0/1	1	1
	P412	Automatic Voltage regulation selection	0~2	1	1
	P413	Automatic- energy-saving selection	0~100%	1%	00
	P414	DC Braking voltage	Depends on models	0.1	Changing
	P415	Braking duty	40~100%	1	50%
	P416	Restart after instant power off	0~1	1	0
	P417	Allowable time of power cut	0~10s	1	5.0S
	P418	Flank restart Current limited level	0~200%	1	150%
	P419	Flank restart time	0~10s	1	10
	P420	Fault restart times	0~5s	1	0
	P421	Delay time for restart after fault	0~100	2	2
	P422	Over torque action	0~3	1	0
	P423	Over torque detection level	0~200%	1	00
	P424	Over torque detection time	0~20.0S	0.1	00
	P425	Reaching Frequency 1	0.00~maximum frequency	0.1	100
	P426	Reaching Frequency 2	0.00~maximum frequency	0.1	5.0
	P427	Timer 1 setting	0~10.0s	0.1	0
	P428	Timer 2 setting	0~100s	1	0
	P429	Constant-speed torque limiting time	0~999.9s	0.1	Changing
	P430	Width of arrival of frequency in hysteretic loop	0.00~2.00	0.1	0.50
	P431	Jump frequency 1	0.00~maximum frequency	0.1	0
	P432	Jump frequency 2	0.00~maximum frequency	0.1	0
P433	Jump frequency hysteresis loop width	0.00~2.00	0.1	0.50	
PLC operation	P500	PLC memory mode	0~1	1	0
	P501	PLC starting mode	0~1	1	0
	P502	PLC running mode	0: PLC stops after running for one cycle 1: PLC stop mode, it stops after running for one cycle 2: PLC cycle running 3: PLC stop mode, cycle running mode 4: PLC operates at the last frequency after running for one cycle.	1	0
	P503	Multi-speed 1	0.00~maximum frequency	0.1	20.0
	P504	Multi-speed 2	0.00~maximum frequency	0.1	10.0
	P505	Multi-speed 3	0.00~maximum frequency	0.1	20.0
	P506	Multi-speed 4	0.00~maximum frequency	0.1	25.0
P507	Multi-speed 5	0.00~maximum frequency	0.1	30.0	

Function	Parameters	Name	Setting Range	Minimum Setting increments	Initial value
PLC operation	P508	Multi-speed 6	0.00~maximum frequency	0.1	35.0
	P509	Multi-speed 7	0.00~maximum frequency	0.1	40.0
	P510	Multi-speed 8	0.00~maximum frequency	0.1	45.0
	P511	Multi-speed 9	0.00~maximum frequency	0.1	50.0
	P512	Multi-speed 10	0.00~maximum frequency	0.1	10.0
	P513	Multi-speed 11	0.00~maximum frequency	0.1	10.0
	P514	Multi-speed 12	0.00~maximum frequency	0.1	10.0
	P515	Multi-speed 13	0.00~maximum frequency	0.1	10.0
	P516	Multi-speed 14	0.00~maximum frequency	0.1	10.0
	P517	Multi-speed 15	0.00~maximum frequency	0.1	10.0
	P518	PLC operation time 1	0~9999s	1S	100
	P519	PLC operation time 2	0~9999s	1S	100
	P520	PLC operation time 3	0~9999s	1S	100
	P521	PLC operation time 4	0~9999s	1S	100
	P522	PLC operation time 5	0~9999s	1S	0
	P523	PLC operation time 6	0~9999s	1S	0
	P524	PLC operation time 7	0~9999s	1S	0
	P525	PLC operation time 8	0~9999s	1S	0
	P526	PLC operation time 9	0~9999s	1S	0
	P527	PLC operation time 10	0~9999s	1S	0
	P528	PLC operation time 11	0~9999s	1S	0
P529	PLC operation time 12	0~9999s	1S	0	
P530	PLC operation time 13	0~9999s	1S	0	
P531	PLC operation time 14	0~9999s	1S	0	
P532	PLC operation time 15	0~9999s	1S	0	
P533	PLC operation direction	0~9999	1	0	
PID operation	P600	PID starting mode	0: PID disable 1: PID start 2: PID start by external terminal	1	0
	P601	PID operation mode selection	0: Negative feedback mode 1: Positive feedback mode	1	0
	P602	PID action set point	0: figure mode (P604) 1: AVI (0-10V) 2: AVI (0-20mA)	1	0
	P603	PID feedback value selection	0: AVI (0-10V) 1: AVI (0-20mA) 2: Reserverd 3: Reserverd	1	0
	P604	PID figure target value setting	0.0~100.0%	0.1%	50%
	P605	PID upper limit alarm value	0~100.0%	1%	100%
	P606	PID lower limit alarm value	0~100.0%	1%	0%
	P607	PID proportional band	0.0~200.0%	0.1%	100%
	P608	PID integral time	0.0~200.0 S.0 means closed	0.1s	0.3s
	P609	PID differential time	0.00.0~20.00 S.0 means closed	0.1s	0.0
	P610	PID action step-length	0.00~1.00Hz	0.1	0.5Hz
	P611	PID standby frequency	0.00~120.0Hz (0.00Hz) 0.00Hz means sleep function is closed	0.1	0.0Hz
	P612	PID standby duration	0~200s	1S	10s
	P613	PID wake-up value	0~100%	1%	0
	P614	PID corresponding value of display	0~9999	1	9999
	P615	PID diqit of display	1~5	1	4
	P616	PID decimal digits of display	0~4	1	2
	P617	PID upper limit frequency	0~max. frequency	0.1	48.00
	P618	PID lower limit frequency	0~max. frequency	0.1	20.00
P619	PID working mode	0: Always work (PID function open) 1: When feedback reaches upper limit (P605), it will work at Min-frequency. When feedback reaches lower limit (P606), PID will begin to work.	1	0	
RS-485 Communication	P700	Communication speed	0: 4800bps 1: 9600 bps 2: 19200 bps 3: 38400 bps		1
	P701	Communication mode	0: 8N1 FOR ASC 1: 8E1 FPR ASC 2: 8O1 FOR ASC 3: 8N1 FOR RTU 4: 8E1 FOR RTU 5: 8O1 FOR RTU		0
	P702	Communication address	0~240	1	0

Function	Parameters	Name	Setting Range	Minimum Setting increments	Initial value
Advanced application	P800	Advanced application parameter lock	0: Locked 1: Unlocked	1	1
	P801	System 50Hz/60Hz setting	0~50Hz 1~60Hz	1	1
	P802	Constant torque or variable torque selection	0: Constant torque 1: Variable torque	1	1
	P803	Over-voltage protection setting	changing	0.1	changing
	P804	Under-voltage protection setting	changing	0.1	changing
	P805	Over-temperature protection setting	40~120℃	0.1	85/95℃
	P806	Current display filter time	0~10.0	0.1	2.0
	P807	0-10V analogue output low end calibration coefAlient	0-9999	1	-
	P808	0-10V analog output high end calibration coefAlient	0-9999	1	-
	P809	0-20mA analogue output low end calibration coefAlient	0-9999	1	-
	P810	0-20mA analog output high end calibration coefAlient	0-9999	1	-
	P811	Compensation frequency point for dead time	0.00~maximum frequency	0.01	0.00
P812	UP/DOWN frequency Memory options	0: memory 1: No Memory	1	1	

## 8.Troubleshooting

Operation Panel Indication	Name	Possible fault reason	Corrective action
OC0 / UC0	Over current during stop	1: Inverter fault	Please contact your sales representative
OC1/UC1	Over current during acceleration	1: Acceleration time is too short 2: V/F curve is not set correctly 3: Motor or motor wire have short circuit to the ground 4: The torque boost is set too fast 5: The input voltage is too low 6: Directly start up the running motor 7: The inverter setting is not correct 9: The inverter fails	1: Increase acceleration time 2: Correctly set V/F curve. 3: Check the insulation of motor and motor wire. 4: Reduce the value of torque boost. 5: Check input voltage 6: Check the load 7: Set tracing startup 8: Enlarge capacity of inverter 9: Sent for repairing
OC2 / UC2	Over current during deceleration	1: Decelerate time is too short 2: Inverter capacity is inappropriately set 3: Whether there is any disturbing	1: Increase deceleration time 2: Enlarge inverter capacity 3: Solve disturbing resource
OC3 / UC3	Over current during constant speed	1: The insulation of motor and motor wire is not good 2: Load fluctuation 3:Fluctuation of input voltage and the voltage is low 4: Inverter capacity is inappropriately set 5: Whether there is a large power motor starting up and leads the input voltage goes down 6: Whether there is a disturbing resource to disturb inverter	1: Check the insulation of motor and motor wire 2: Check load situation and mechanical lubrication 3: Check input voltage 4: Enlarge the capacity of inverter 5: Increase capacity of transformer 6: Solve disturbing resource
OU0	Over voltage during stop	1: The deceleration time is short 2: Inverter capacity incorrectly set 3: Disturbing	1: Check the power supply voltage 2: Sent for repairing
OU1	Over voltage during acceleration	1: Abnormal power supply 2: Peripheral circuitry is incorrectly set (switch control on or off, etc.) 3: Inverter fault	1: Check the power supply voltage 2: Do not use power supply switch to control the inverter on or off 3: Sent for repairing
OU2	Over voltage during deceleration	1: Power supply voltage abnormal 2: Energy feedback load 3: Braking resistor incorrectly set	1: Check the power supply voltage 2: Install braking unit and resistance 3: Affirm resistance setting again

Operation Panel Indication	Name	Possible fault reason	Corrective action
OU3	Over voltage during constant speed	1: Decelerate time is too short 2: Power supply voltage abnormal 3: Over load 4: Braking resistor incorrectly set 5: Braking parameter is incorrectly set	1: Increase deceleration time 2: Check the power supply voltage 3: Check braking unit and resistance 4: Set Braking resistor over again 5: Correctly set parameter, e.g. braking tube voltage, etc
LU0	Under voltage during stop	1: Power supply voltage abnormal 2: Phase missing	1: Check the power supply voltage 2: Check power supply and switch whether there is phase missing
LU1	Under voltage during acceleration	1: Power supply voltage abnormal 2: Phase missing 3: There is large load power start up in the input	2: Check whether peripheral setting bad connection leads phase missing 3: Please use independent power supply
LU2	Under voltage during deceleration		
LU3	Under voltage during constant speed		
OL0 during stop	Inverter overload	1: Overload 2: Acceleration time is too short 3: Torque boost is too fast 4: V/F curve incorrectly set 5: Under voltage of input 6: Before motor stops, inverter starts up 7: Fluctuation or blocking in loading	1: Reduce the load weight or replace larger capacity inverter 2: Increase acceleration time 3: Reduce torque boost rate 4: Set V/F curve over again 5: Check input voltage, increase inverter capacity 6: Adopt tracing startup mode 7: Check load condition
OL1 during acceleration			
OL2 during deceleration			
OL3 during constant speed			
OT0 during stop	Motor overload	1: The motor for use under overload 2: Acceleration time is too short 3: Motor protection setting is too small 4: V/F curve is incorrectly set 5: Torque boost is too fast 6: Bad motor insulation 7: Motor setting is too small	1: Reduce the load weight. 2: Increase acceleration time 3: Increase protection setting 4: Correctly set V/F curve 5: Reduce torque boost rate 6: Check motor insulation and replace motor 7: Use larger inverter or motor
OT1 during acceleration			
OT2 during deceleration			
OT3 during constant speed			
ES	Emergency stop	1: Inverter is in Emergency stop condition	1: After release Emergency stop, start up as regular procedure
CO	Communication error	1: Communication line connection has problem 2: Communication parameter is incorrectly set 3: Transmission format is wrong	1: Perform wiring of the RS-485 terminals properly 2: Set parameter over again 3: Check data transmission format
20	4-20mA wire broken	1: Terminal is loose; signal input line is bad connected	1: Perform wiring of the 4-20mA terminals properly.
Pr	Parameter write error	Parameter setting is wrong	After stopping operation, make parameter setting.
Err	Wrong parameter group	The parameter does not exist or the factory setting parameter	Quit this parameter